

D1101KH flush mounting housing (backbox)

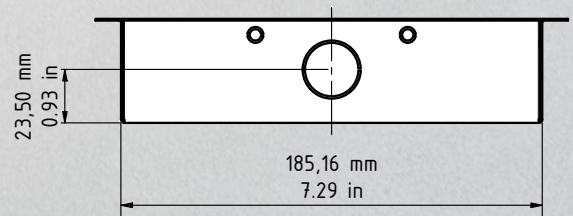

Important note for cavity mounting (e.g. in pedestals and mailboxes):

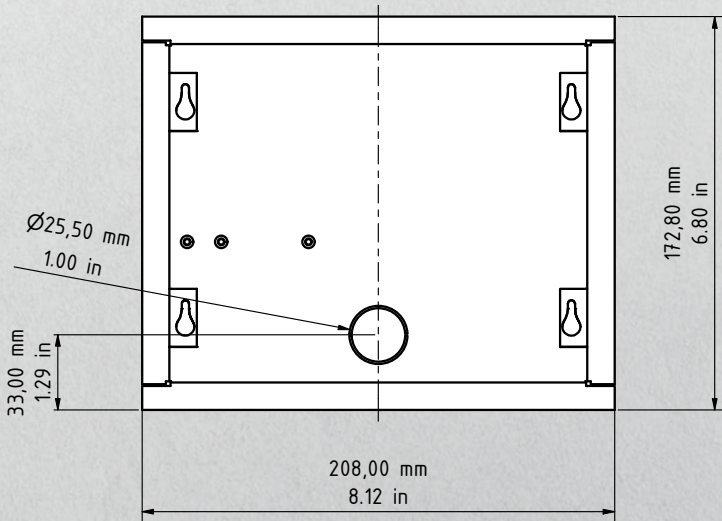
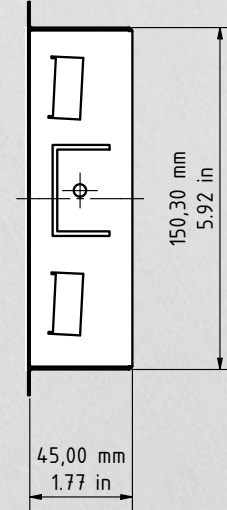
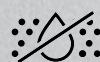

To protect the electronic units, please ensure that the technical components are protected against dripping and running water caused by condensate or entering the mounting space through openings.

To protect the electronic units, ensure that the mounting space inside is not accumulating water.



Sufficient air circulation must be ensured, as well as unobstructed drainage of water at the base of the installation.

Failure to do so will result in warranty being declined.

General tolerance DIN/EN 2768 -mK
Wall cut-out dimension +4 mm/0.15 in